

<b>N° D'ART.</b>	45270
<b>DESCRIPTION</b>	Quick-Point® 52, Pions de positionnement, Ø 16 mm, pour une distance de 52 mm entre les pions
<b>DATE DE PUBLICATION</b>	04.05.2021

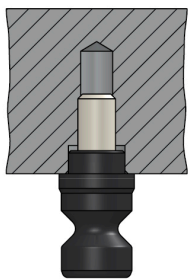

52

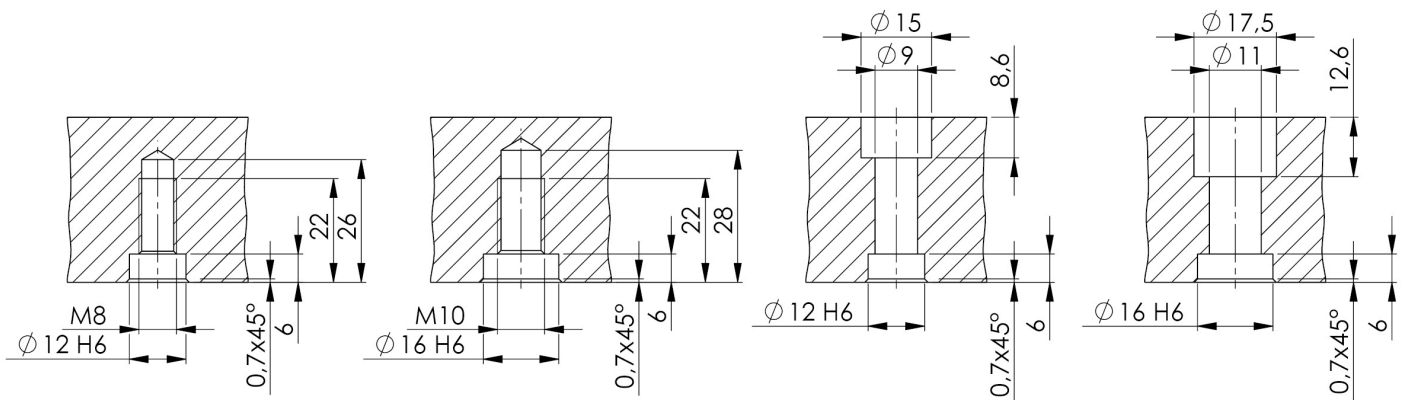
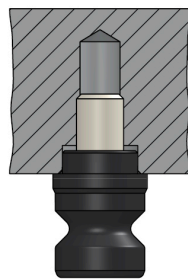

96

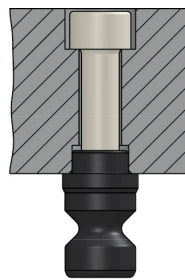

52

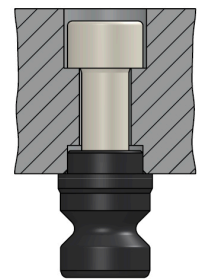

96

Mit Gewindestift /  
with threaded pin

Mit Schraube /  
with screw

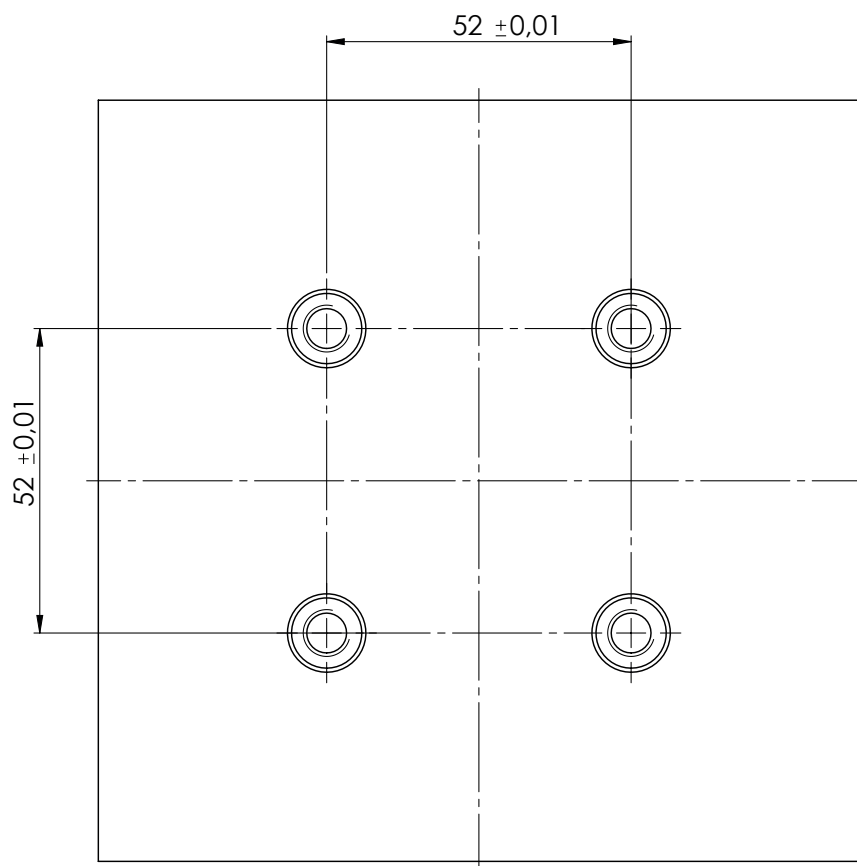

**Les pions doivent être positionnés dans leurs propres dispositifs de serrage et montages avec une précision dimensionnelle de 52 mm ± 0,01 mm.**